

Safety Attention Notes

- ◎Please read the instructions thoroughly before installing or operating the unit.
- ◎Please do not put the machine on an unstable table or mounting bracket.
- ◎Please prevent all liquids or other contaminating material from entering into the dome housing.
- ◎When connecting to the power source, please follow all electric safety standards and only use the power supply designated for this device. The speed dome's RS-485 and video signal uses TVS technology to protect it from strong electric surges. This technology prevents damage to the device resulting from impulse signals such as lightning strikes or surges under 500W power. Allow for enough distance between the RS-485 and video signals and high-voltage equipment or cables during the transmission process. Please do not power the unit until all connections are secure and installation is complete.
- ◎Avoid screening very bright objects (such as the sun or light fittings) directly for protecting the camera's CCD.
- ◎When the machine is not operating properly, do not casually repair it. Refer to the instructions for information about how to service or repair or call the professional maintenance man.

INDEX

<i>I Introduction</i>	3
<i>II Technical Data</i>	3
<i>III Setting, Installation, Connection</i>	4
3.1 <i>Dome Address, Transmission Speed, Protocol Setting</i>	4
3.1.1 <i>Speed Dome Camera Address Setting</i>	5
3.1.2 <i>Speed Dome Camera Communication Protocol Setting</i> -	5
3.1.3 <i>Speed Dome Camera Transmission Speed Setting (Baud Rate Setting)</i>	6
3.1.4 <i>RS-485 Bus Matching Resistance</i>	6
3.2 <i>Installation, Connection</i>	6
3.2.1 <i>Installation Requirement</i> -.....	7
3.2.2 <i>Outdoor Speed Dome Camera Wall Hanging Installation</i>	7
3.2.3 <i>Indoor Hemisphere Dome Camera Recessed Installation</i>	10
<i>IV. Instruction for Keyboard to Control Speed Dome Camera</i>	12
4.1 <i>Setting and Adjusting Preset Position</i>	12
4.1.1 <i>Setting Preset Position</i>	12
4.1.2 <i>View Preset Position</i>	13
4.2 <i>Dome Pattern Tours</i>	13
4.2.1 <i>Preset Position Parameter Setting</i>	13
4.2.2 <i>Pattern Tours Setting</i>	15
4.3 <i>Auto Scanning (2points scanning,360°scanning)</i>	16
4.3.1 <i>2 Points Scan</i>	16
4.3.2 <i>360° Scan</i>	16
4.4 <i>Guard Location</i>	17
4.4.1 <i>Setting the Guard Location</i>	17
4.5 <i>Objective Tracking</i>	18
4.6 <i>Camera Control</i>	18
4.6.1 <i>Zoom Control</i>	18
4.6.2 <i>Focus Control</i>	18
4.6.3 <i>Iris Control</i>	19
4.6.4 <i>Auto Backlight Compensation</i>	19
4.6.5 <i>Auto White Balance</i> -.....	19
<i>V. Camera Menu Setting</i>	19
<i>VI. Protocol Order Chart</i>	22
6.1 <i>PELCO-D, PELCO-P Protocol Order Chart</i>	22
6.2 <i>SAMSUNG, KALATEL Protocol Order Chart</i>	23
<i>VII Exception Handling</i>	24
<i>VIII. Address-Binary code chart</i>	24

I Introduction

Many thanks for purchasing our speed dome, an intelligent, high-speed dome camera with a high-performance DSP camera and sophisticated zoom lens. It is an advanced technological surveillance product combining an all-direction variable speed dome and digital decoder all in one unit. It can aim quickly and scan continuously, making omni-directional and non-blind-spot monitoring into reality. Additionally, it can quickly adapt to changing environments with its 18x optical and 12x digital zoom with precise stepping motors. The advanced stepping motor technologies drive the dome to rotate smoothly, respond sensitively and aim precisely. The speed dome camera has memorizing function, which can auto resume to previous working status after the power on. Use the high-performance speed dome "When it Counts."

All of the features make the intelligent high-speed dome camera fit for a wide range of applications such as intelligent building, bank, street of city, airport, station etc.

II Technical Data

2.1. Technical Parameter of Intelligent High-speed Dome

Model	Outdoor Day/Night Speed Dome	Indoor Speed Dome
Power Supply	AC24V±5%	
Operating temperature	- 40°C~+60°C	0°C~+40°C
Operating moisture	≤95%	
Power consumption	20W	
Communication	RS485 bus	
Communication transmission speed	1200/2400/4800/9600bps	
Horizontal rotation speed	0.4° – 280°(1-64 grade shift gears)	
Horizontal rotation range	360° unlimited rotation	
Tilt rotation range	90°	
Auto flip	Rotates 180° when camera tilts to the vertical position	
Auto zoom speed control	Control speed auto-adjusted according to zoom length changing	
2 points scan	Can set freely	
2 points scan speed	1 – 64 grade available	
Preset Positions	128 pcs	
Running to preset speed:	1 – 64 grade available, 0.4° -280°	
Dwell time at preset position	1 – 60s available	
Cruise Tour:	8 group	
Cruise Points Qty per cruise group	16 preset positions	
Fan, Heater	Fan and heater auto-starts 24VAC	NIL

2.2. Camera Parameter for High-speed Dome: (Built in SONY Camera).

Model	Outdoor Day/Night Speed Dome	Indoor Speed Dome
Mode	1/4" Sony Exview (Day/Night) CCD	1/4" Sony Exview CCD
Sync	Internal/ external	
Scan	2:1 Interlace	
Resolution	>480 lines	
Minimum illumination	0.7lux/0.01lux (b/w mode)	0.7lux
Iris	Auto/manual	
Focus	Auto/manual	
Zoom	216 X (Optical 18x; Digital 12x)	
Focal length	f=4.1-73.8mm, F=1.4-3	
Angle of view	47°(wide) , 2°(Tele-)	
Backlight compensation	Backlight compensation	
White balance	Auto	
Gain	Auto	
Signal	PAL/NTSC	
S/N ratio	>55dB	
Video signal output	1.0±0.2Vp-p	

III Setting, Installation, Connection

3.1 Dome Address, Transmission Speed, Protocol Setting

Before the dome is installed, the communication protocol, baud rate and dome address, should be confirmed. Set the code switch, keeping the setting consistent with the control system. The relative code switch site and connecting wire are diagramed below for reference.

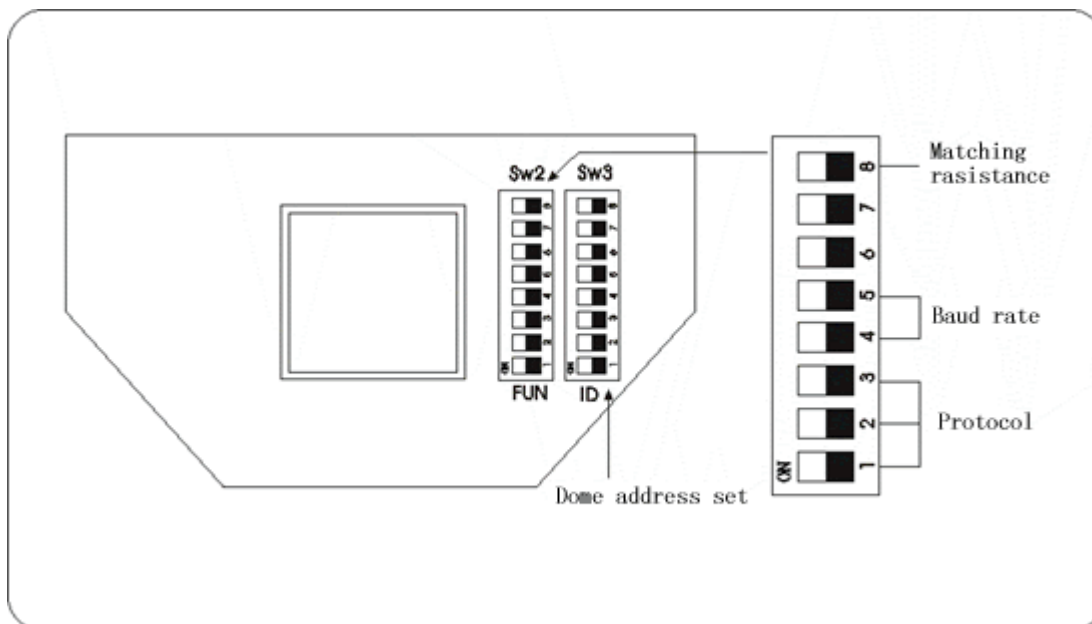

3.1.1 Speed Dome Camera Address Setting

The address code for the speed dome should be properly set before use to ensure accurate operating order of the controller at the control center and to control many dome cameras. The address code is set by 8 bits of SW3 on PCB board. The 8 bits switch adopts the 8421 binary coded decimal system. The largest value is established at 256. 1 means ON status and 0 means OFF status. Each dome address code and keyboard relative screen display mode is represented in the chart below (see the following figure and the address/digits in following chart)

Switch	Binary code	Dome Address	Keyboard Screen Display	Display after Pressing CAM key
	00000000	1	MON XX CAM XXXX Data 0001	MON XX CAM 0001 Data 0000
	00000001	2	MON XX CAM XXXX Data 0002	MON XX CAM 0002 Data 0000
	00000010	3	MON XX CAM XXXX Data 0003	MON XX CAM 0003 Data 0000
	00000010	4	MON XX CAM XXXX Data 0004	MON XX CAM 0004 Data 0000
	00000100	5	MON XX CAM XXXX Data 0005	MON XX CAM 0005 Data 0000

With reference to the above chart: When all code switches are under “OFF” status on speed dome, address code is 1. When you input Numerical key No.1 on control keyboard, then press CAM key for confirmation showing that set keyboard address as No.1 control address., At this time, keyboard can control speed dome camera(its control address is 0001). Other address is to be set as above.



- When “DATA” column not showing “0”, “DATA” column means the address of dome camera
- When “DATA” column showing “0”, “CAM” column means the address of dome camera



After establishing the address, please restart the unit to save changes.

3.1.2 Speed Dome Camera Communication Protocol Setting -

The 1st, 2nd and 3rd bits in SW3 are used to set communication protocol (see following figure)

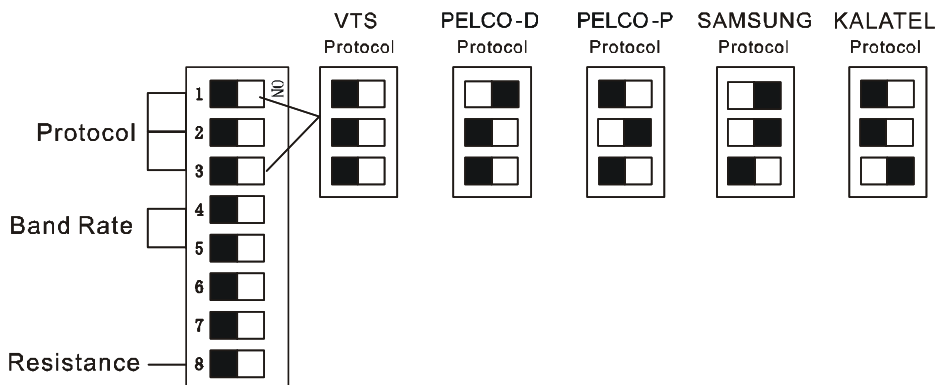



After establishing the communication protocol, please restart the unit to save changes.

3.1.3 Speed Dome Camera Transmission Speed Setting (Baud Rate Setting)

The 4th and 5th bits of SW2 on the PCB board are used to set the baud rate (see following figure). The default baud rate setting is 9600.

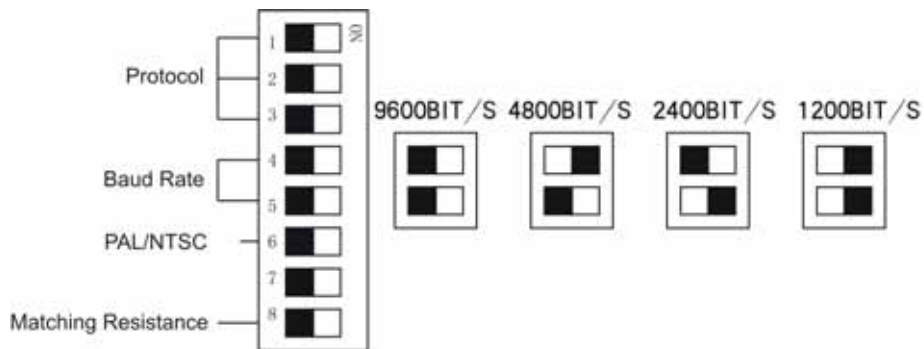

Baud Rate Options: 1200BIT/S 、 2400BIT/S 、 4800BIT/s、 9600BIT/s



After establishing the transmission speed , please restart the unit to save changes.

3.1.4 RS-485 Bus Matching Resistance

For central controlling, in order to avoid reflex and impact of signal from RS-485,the connection of device farthest away from the controller need set matching resistance. There is an end matching resistance switch on SW3. The 8th bit of SW3 shows ON status (see chart below) which means the BUS matching resistance has been connected.

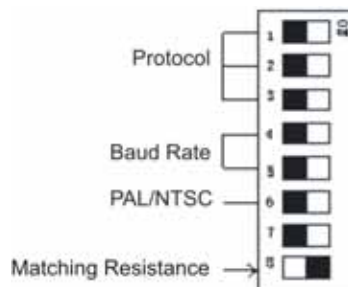

When dome is out of control or doesn't work under RS-485 BUS control status, please set switch of matching resistance as ON status so that we can clear up bad phenomenon.



If dome address, baud rate and communication protocol is required to be reset after finish installation, please ensure dome is under is under power off status.

3.2 Installation, Connection Attention!

1. Installation should only be handled by a qualified CCTV maintenance man.

2. For detailed connection information, please refer to silk-screen print instruction on PCB and installation guide or manuals.
3. Don't scratch the dome cover
4. For a clear image, the dome cover should be cleaned periodically. When cleaning, position your hand to hold dome's outer loop to prevent finger sweat acidity from corrupting the surface of the dome. If the dome is scratched, it will affect image quality. Therefore please use a soft dry cloth or similar products to clean its outer surface. If the dust is heavy, you can use a neutral cleanser. Any advanced furniture cleanser can be used to clean the dome exterior.

Installation Preparation

3.2.1 Installation Requirement-

- Installation should be handled by a qualified service agent and should comply with all local regulations, Service personnel should forecast potential problem such as falling objects, outer breach, building vibration or other similar conditions.
- Check for all necessary materials, and ensure if the selected installation location is suitable for the speed dome.

3.2.2 Outdoor Speed Dome Camera Wall Hanging Installation

• Wall Hanging Installation

ATTN: Installation locations should endure 5 times weight of total weight (dome camera, mounting bracket and mounting base) to avoid in shaken images.

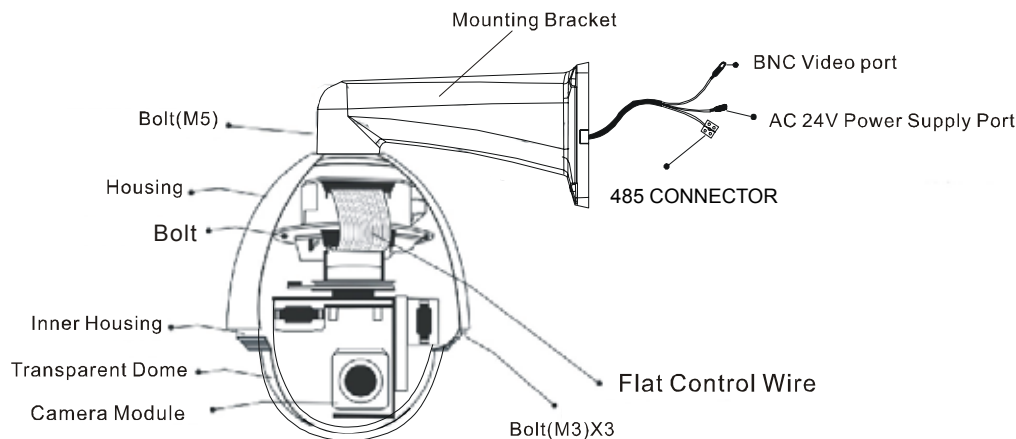

Assemble Sketch

- a. Set wall bracket mounting on the wall. Draw out center site of the hole on the wall against bracket sample
- b. Use drill to make 4 holes with the M8 size at the designated site. Screw in M8 bolt for mounting
- c. Put power, communication and video lines through bracket hole, leaving enough wire length Maneuverability.
- d. Fix the bracket to the wall with 4 M8 bolts and mounting tray.

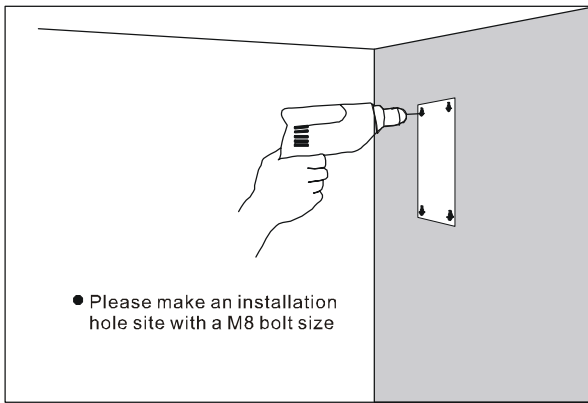

• Housing Installation

- a. Remove housing from the packing and put the cable into the bracket from bracket top. Install G1 1/2 bolt on the top of housing into the bolt of wall bracket. At the same time, use two M8 bolt to secure in place.

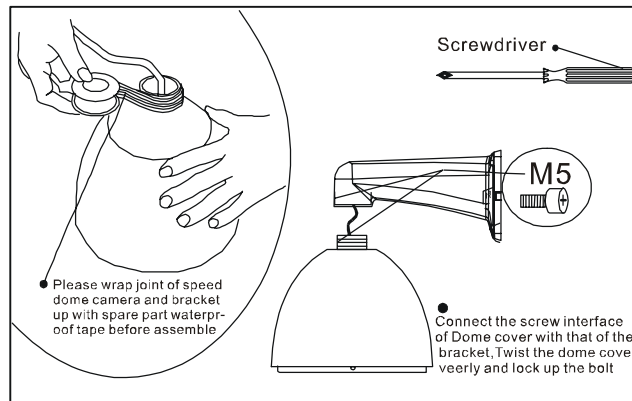

Camera Module Installation

- Install under the condition that the power is off
- Loosen the two M5 bolts on the bracket, which are located in the inner housing.
- Take the camera module from the packing, and check if connecting wire plugs are loose. Set code switch of the dome.
- Secure the camera module (use one hand to hold stepping motor, preventing it from moving.). Insert the wire terminal into the outlet on the end of camera module. Align two holes on the camera module base with the two M5 bolt of the connecting bridge. Twist the camera module in to place. Ensuring the two M5 bolts reach the end of bar hole. Tighten the two M5 bolts to make camera module fixed on the upper housing.

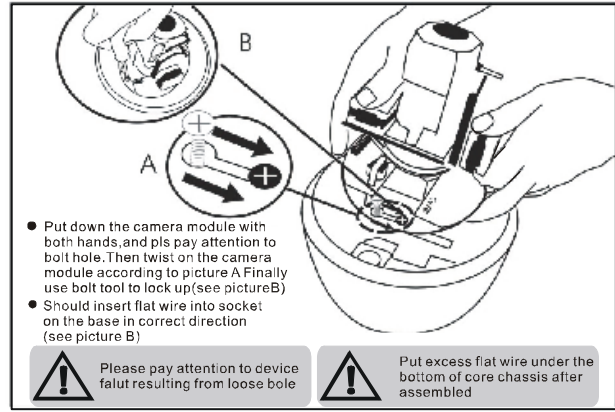
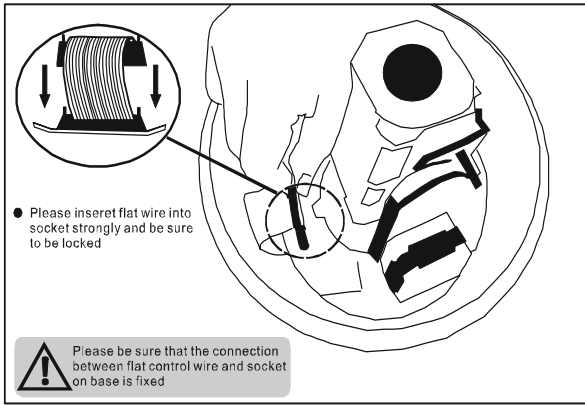

Connection (Outer connecting wire)

Connect BNC video interface of outdoor speed dome camera with video wire (BNC). Connect power supply line with set power line (AC24V).

Should not connect positive and negative polarity of RS485 contrarily. A RS485 positive, B RS 485 negative polarity. If connect RS485 contrarily, will not control outdoor speed dome camera

Electricity

- Check the polarity of the plug and outlet, then check all connecting wires
- Domes enter self-inspection, and carry out a replacement program when first powered on. (During the replacement process, self-inspects horizontal and tilt rotation to starting point before camera lens extend, then make a horizontal 360° and tilt 90° rotation). After the dome stops completely, the self-inspection is completed and dome is ready to be controlled.

Dome Mounting

- Please make 3 bolt holes aim at housing bolt holes, and use three M3 bolts to fix.
- Use soft cloth to wipe off dust and smudges of transparent dome, avoid scratching the dome

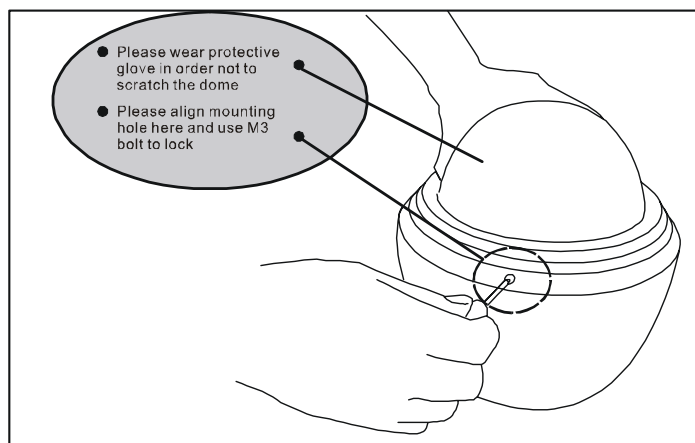

3.2.3 Indoor Hemisphere Dome Camera Recessed Installation

ATTN: Installation locations should endure five times the total weight of the camera assembly (dome camera, mounting bracket and mounting base) to avoid in shaken images. Installation ceiling must be strong and has no peeling phenomenon.

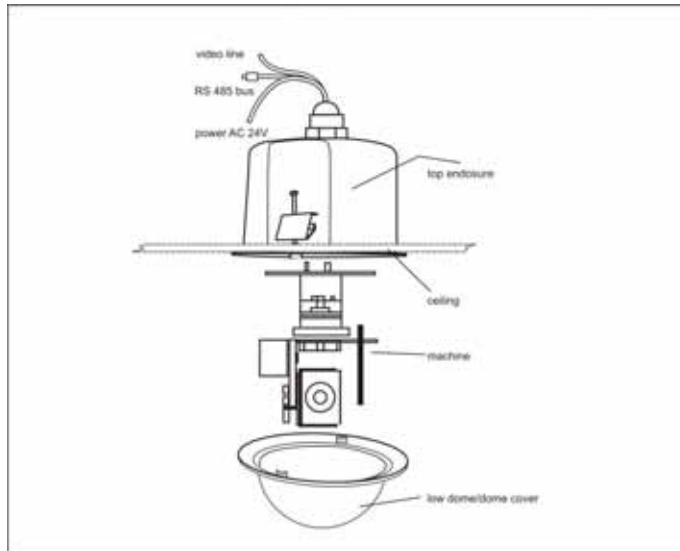

- A. Draw out center site of the hole on the ceiling against embedded upper housing sample
- B. Use drill to make hole on the ceiling

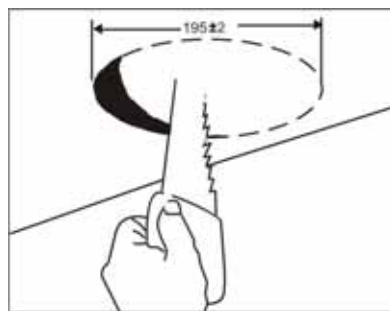

• Housing Installation

- A Take out the housing from the carton, adjust the thickness of bolt reed more than that of ceiling.
- B Stick 3 rings to housing, and install the upper housing in the round hole of the ceiling, connecting flange edge with the ceiling surface closely.
- C Use screwdriver to rotate the bolt of the ring, making the ring stick to the ceiling in order to connecting flange edge with the ceiling surface closely.

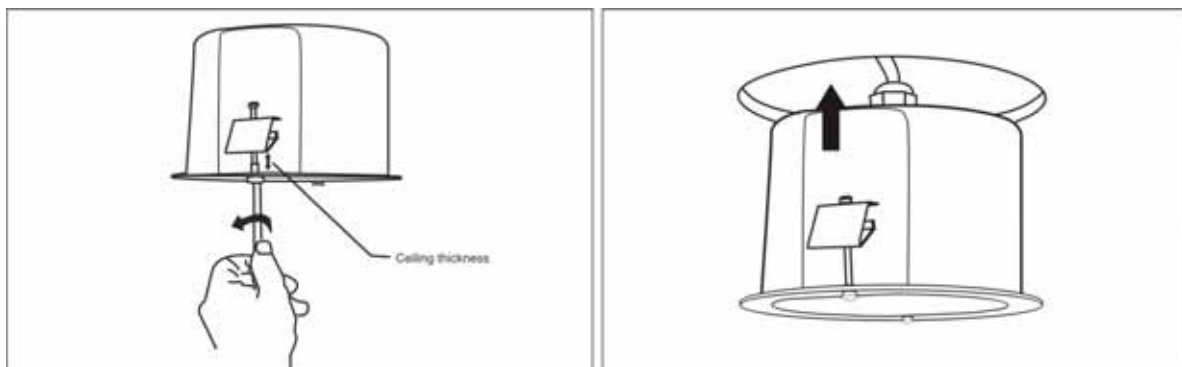

Camera Module Installation

- Conform power off before installing.
- Loosen the two M5 screw on the bracket, which are located in the inner housing .
- Take the camera module from the packing carton, and check if connecting wire plugs are loose. Set code switch of the dome camera.
- Secure the camera module (use one hand to hold stepping motor, preventing it from moving.). Insert the wire terminal into the outlet on the end of camera module. Align two bar holes on the camera module base with the two M5 bolt of the connecting bridge. Twist the camera module upward ensuring the two M5 bolts reach the end of bar hole. Tighten the two M5 bolt to make camera module fixed in the upper housing.

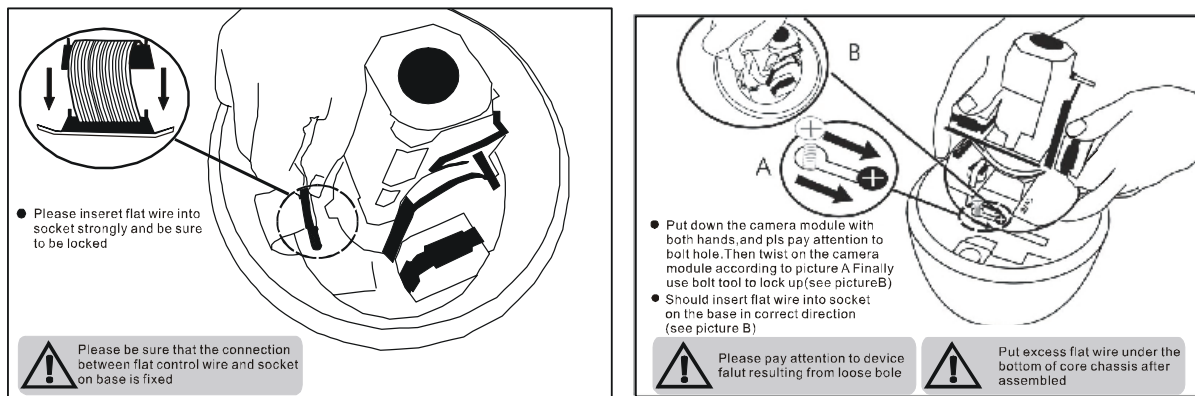

Connection (Outer Connecting Wire)

Connect BNC video interface of dome camera with video wire (BNC) which is finished installing. Connect power supply line with power line (AC24V) which have been set well.



Should not connect positive and negative polarity of RS485 contrarily. A RS485 positive, B RS 485 negative polarity. If connect RS485 contrarily, will not control indoor speed dome camera

Electricity

- Check the polarity of the plug and outlet, then check all connecting wires.
- Domes enter self-inspection, and make a horizontal 360° and tilt 90° rotation to test camera lens, dome horizontal and tilt electronic& mechanical structure. Then carry out a replacement program rotating to starting point. After the dome stops completely, the self-inspection is completed and dome is ready to be controlled.

Dome Mounting

- Use soft cloth to wipe off dust and smudges of transparent dome cover, avoid scratching it
- Align two holes on the dome cover edge with the two connection points of the metal upper housing.

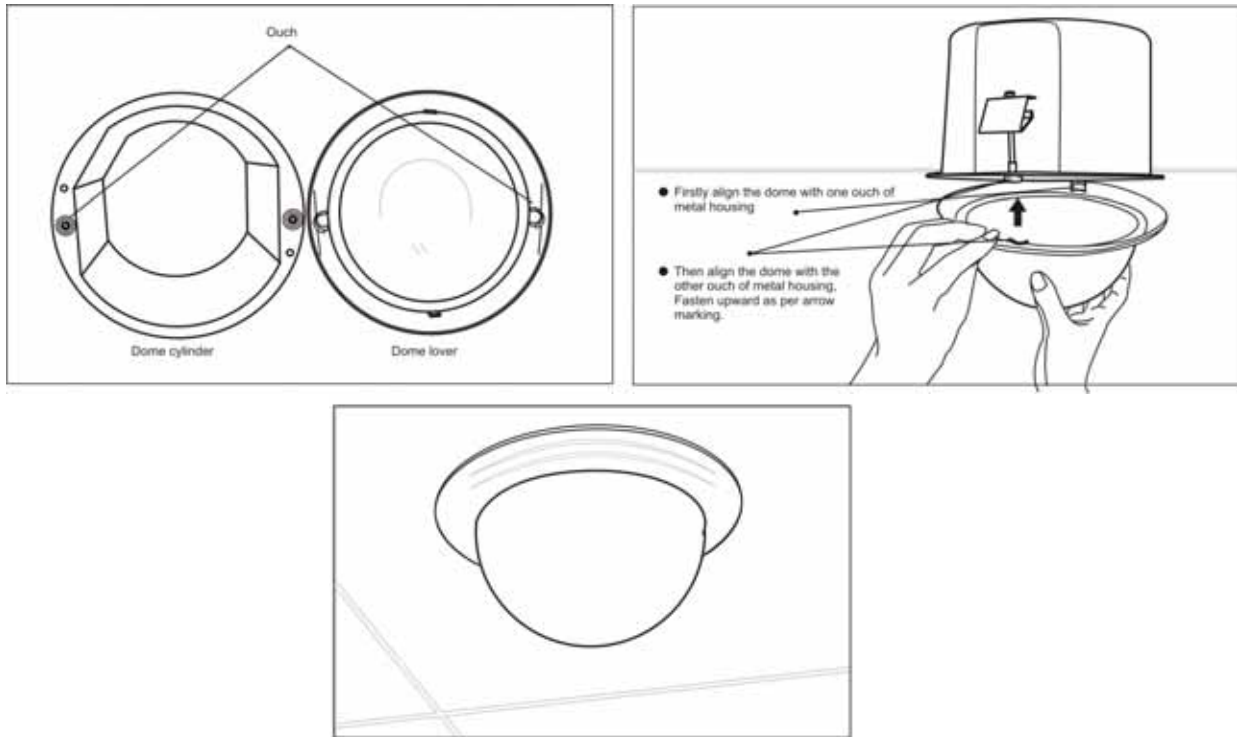

ATTN: Please ensure that the dome cover and metal housing are connected firmly

IV. Instruction for Keyboard to Control Speed Dome Camera

Through the keyboard controlling the high speed dome camera can implement the intellectualized function. Although different controller system have different operation ways, please follow the manufacturer' manual any other special requirement and operation ways, please contact with dealers. (The keyboard controller protocol is set as the default protocol for the speed dome.)

4.1 Setting and Adjusting Preset Position

The Preset function is save the dome's default level angle, lean angle and camera focal length in digital form (1-128) in EMS memory, and read the saved parameter, the dome and camera can run the preset positions when it is required. Operator can save and adjust preset positions by using the control keyboard; the speed dome can support 128 preset positions.

4.1.1 Setting Preset Position

Adjust the speed dome camera to the desired position using the keyboard joystick/rocker (including location, camera zoom, focus and iris), and then input the required preset position number. The inputted preset position value No. is displayed at the bottom of the LCD "DATA" area. Press Shift + Call, to confirm position. The preset position at "DATA" disappears showing that the preset position was set successfully.

For example: Set No.1 preset position

1. Adjust the Main Menu screen, Press CLR to Clear the data. The keyboard displays:

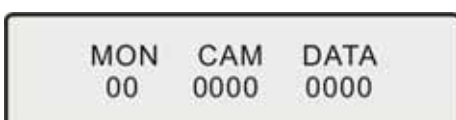

2. Enter the Preset Position Number you wish to set
Ex. Set Preset Position No. 1, the keyboard displays:



Displays the Preset Position Number (1-128)

- Adjust the speed camera to the desired position including location, camera zoom, focus and iris.
- Press Shift + Call for final confirmation.

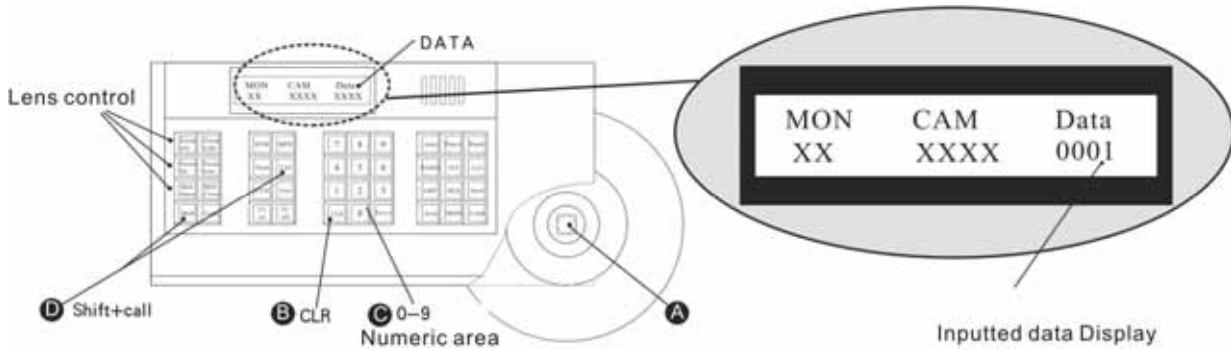

4.1.2 View Preset Position

Use the keyboard to view the preset position. (Preset positions are saved in advance). Input the preset position you would like to view, Data area will display preset position number. Press Call key, the dome will move to the target place.

For example: View No.5 preset position

- In the Main Menu, Press CLR to clear the data.

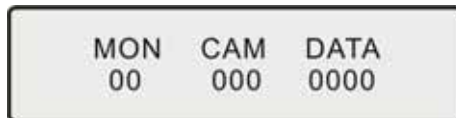

- Input the preset position you would like to view.
Example: View preset position No. 5

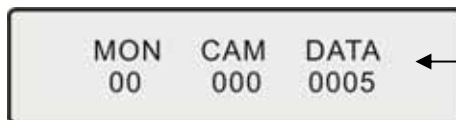

Displays the Preset Position Number (1-128)

- Press the CALL key. The dome will move to the Preset Position No. 5

4.2 Dome Pattern Tours

Pattern Tours are a key function of the speed dome camera. You can layout the preset position order in the pattern tours through our advanced program. Using the control keyboard you set the rotation speed for each preset position and dwell time at each preset position. Only an outer command unit can transfigure the speed dome camera into a pattern tour program route.

4.2.1 Preset Position Parameter Setting

speed dome camera has the capacity to set up to 128 preset positions through the keyboard. It can set a running speed at each preset position from 0.4/s to 280/s (1-64grades) and dwell time from (1-60seconds). Note: speed dome can rotate at low speeds and at fast speeds. Its speed can be divided into 64 grades. 1 is the lowest speed and 64 is the fastest speed.

To get to the control keyboard Main Menu Press Exit until the screen displays:



1. In the Main Menu, Press the FUN key once. Keyboard displays:

1)Speed dome .Setup
Number:0001

Press CLR to delete previous data. Input required SPEED DOME address code XXXX (1-1024) for control. Press Enter for

2. Enter the correct Speed Dome Unit and Press Enter.

Example: Preset Position for Speed Dome 3. Keyboard displays:

1) Speed Dome Setup
Number:0003

Displays the Speed Dome Address (1-1024)

3. Now the control Keyboard displays:

Running speed (1-64) →

1.Position:000
Speed:00 Time:00

← Dwell time(1-60)

Preset position (1-128)

Press F1 key on the keyboard to move the cursor up and down

4. Press CLR key to delete previous data before programming to a new preset position.
5. Enter desired Preset Position and Press Enter.
6. Press F1 to get to Speed. Using the number keys enter the desired running speed.
7. Press F1 to get to Time. Using the number keys enter the desired dwell time.

For example: Set the running speed of preset position No. 6 as Grade 64 (fastest speed), dwelling time is 5 seconds. Set the running speed of preset position No.2 as Grade 10, dwelling time is 10seconds.

1. Press the FUN key once.
2. Press CLR to clear the data.
3. Input 06 (Note: Setting the Preset Position No. 6) press the Enter Key to Confirm.
4. Press the F1 key to move the cursor to Speed:00←
5. Input 64, press Enter
6. Press the F1 key to move the cursor to Time:00←
7. Input 05, press Enter
8. Press F1 to move the cursor back to 1.Position:001←
9. Press CLR to delete 0006
10. Input 02, press Enter
11. Press the F1 key to move the cursor to Speed:64←
12. Press CLR to delete 64
13. Input 10, press Enter
14. Press the F1 key to move the cursor to Time:05←
15. Press CLR to delete 05
Input 10, press Enter

4.2.2 Pattern Tours Setting

Control keyboard can set pattern tour groups for the speed dome camera.

Before setting the Pattern Tours please set all preset positions in advance. If the preset positions are not set the pattern tour will default to the pattern tour parameter. Note: SPEED DOME can set 8 cruise groups.

1. Press the FUN key once, control keyboard displays:



2. Enter the correct Speed Dome Unit and Press Enter.

Example: Set Pattern Tour for Speed Dome Unit 02. control Keyboard displays:



3. Press the FUN key once, now the control keyboard displays:



4. Input a Group number using the number keys, press Enter, control keyboard displays:



5. Input desired Pattern Tour for the Group.

Example: Desired pattern tour is Preset Position No. 1 – 2 – 3 – 4 – 5 – 6

The control keyboard displays:

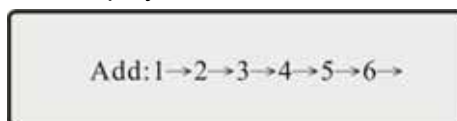

6. Press Enter to confirm Pattern Tour.

Remark: When completed, Press F2 to close and exit. To Start the Scan: In the Main Menu enter the Group Number and Press SCAN.

- This dome can set 8 cruise group, Max 16 cruise points/each group(1-128 points at any preset position).
- Set preset position at the cruise group
- Dwell time at each preset position can be different(1-60 seconds), The speed to each preset position can be different(1-64 grades)
- If start No. 01 cruise group, will auto scan by points from No1 to No.16 preset position.

Two pattern tours styles can be used:**A .To-and-from scanning**

1-2-.....-16-1-2-.....-16-1-..... Make an auto circle scanning by points.

Press EXIT key and exit to default status of the keyboard.

Input cruise No adjust key SCAM into to-and-from scanning

B. Cruise scanning

1-2-.....-15-16-15-.....-2-1-2-.....-15-16-15-...Make an auto cruise scanning

Press EXIT key and exit to default status of the keyboard. Then input cruise group No and

then input Shift + Scan to put system into cruise scanning.

4.3 Auto Scanning (2points scanning,360° scanning)

The operator can also run a simple point-to-point scan (also called back-and-forth scanning). To do this, set Preset Point A first (at the same time set the dwell time at Point A), and then set Present Point B (at the same time set the dwell time at Point). Finally execute an outer command to scan between points A and B.

4.3.1 2 Points Scan

1. To set Point A. Move the joystick to the desired position.
2. In the Main Menu enter a dwell time for Point A. Example: If Dwell time is 1 seconds the control keyboard displays:

MON	CAM	DATA
00	0000	0001

3. Press PAN A.
4. To set Point B. Move the joystick to the desired position.
5. In the Main Menu enter a Dwell time for Point B.
6. Input the grade Speed (1-64) and Press AUTO

Example: Set dwell time of Point A as 1 seconds, dwell time of Point B as 3 seconds. Make the scanning at 32-grade speed between the two points

- a) Move control joystick to Point A of scanning
- b) Input 01, then press Pan-A on the keyboard after two seconds
- c) Move control joystick to Point B of scanning
- d) Input 03, then press Pan-B on the keyboard after two seconds
- e) Input 32 grade, then press AUTO key.

This will scan starting at Point A to Point B at a scanning rate of 32 grade stopping at Point A for 2 seconds and Point B for 3 seconds.

4.3.2 360° Scan

The Operator can also start an auto cruise scan. This scan will rotate 360° from the desired position.

1. In the Main Menu, input desired cruise group No.

Example: Desired Group No. is 4 the control keyboard displays:



2. Press Shift + Scan to place PTZ into cruise scanning.

OR

1. Move the joystick to desired position.
2. Input the running speed (1-64) and then input Shift + AUTO key.

Note: When speed dome camera is under the auto scanning status, you can use the joystick if you want it to stop scanning.

4.4 Guard Location

The guard location is an important position that the speed dome camera will come back to automatically when there is no operation for a defined period. The user can set a guard location and control the waiting time to the guard location, starting and stopping (1-255S) before allowing the camera to return to the guard location.

4.4.1 Setting the Guard Location

Intelligent speed dome can set a guard location and waiting time.

Use the control keyboard to set the guard location and its waiting time.

Turning the Guard Location On/Off and Setting delay time to Guard Location

1. To set the guard location to start or stop (control keyboard recognizes this action as a Switch): ON Start OFF Stop

Press F1 ON Startup the guard location

Press F2 OFF Stop the guard location

Example: Press F1 ON to start up guard location. Dome will rotate to set position within XX seconds.

2. The keyboard default status displays the Main Menu. In the Main Menu screen, press the FUN key once, control keyboard displays:



3. Press Enter to Confirm.

4. Press the FUN key three times, control keyboard displays:



5. Input the desired waiting time using the number keys:

Example: After inputting time: 05, press Enter.

4) Watch Position
Time: 005 Switch

Setting the Guard Location

1. When the keyboard is under default (Main Menu) status, press the FUN key once, control keyboard displays:

1) Speed Dome Setup
Number: 0000

2. Press Enter to confirm.

3. Press the FUN key two times, control keyboard displays:

3) Press Enter Key To
Setup Watch Position

4. Move the joystick/rocker to the target position you would like to set as the Guard Location.

5. Press Enter to set the Guard Location.

The position is set as the guard location.



The above setting adopts "VTS" protocol of Control keyboard. If dome camera protocol is set as PELCO-D or PELCO-P, Control keyboard should be set as PELCO-D or PELCO-P protocol. Setting and adjusting preset position is same as to the above. Other function parameter see PELCO protocol menu for setting.

4.5 Objective Tracking

An user can rotate the camera lens up, down, left and right to view objects through the field of vision using the control keyboard. In addition, a user can adjust focal length to change the angle of view or the size of the objects. When in auto - iris and auto-zoom mode, the camera adjusts automatically to get a clear picture with changing image environments.

Focus/Rotate Auto Speed Controls

When manually adjusting the zoom length or focal distance at longer ranges, a typical PTZ dome may move too quickly resulting in the loss of important images. The out door speed dome is especially designed to adjust the sensitivity of the Pan and Tilt controls making navigation easy and intuitive at these long ranges.

Auto Flip

The speed dome's auto-pan rotation with 180-degree flip capabilities automatically rotates the camera 90° when the camera tilts to the vertical position. This feature enables the continuous monitoring of an object as it passes through the field of vision.

4.6 Camera Control

4.6.1 Zoom Control

The user can adjust the advanced zoom feature to acquire needed image through control keyboard. The speed dome features a 216x zoom magnification (18x Optical and 12x Digital).

4.6.2 Focus Control

The speed dome's default setting is for auto-adjust focusing. Under special conditions, a user can adjust the focus manually meet the required image effect.



The speed dome will not auto-focus the target object under the following conditions:

- a. The object is not on the center of the picture.
- b. Attempting to view images that are far and near at the same time
- c. Object is strongly lighted object, such as neon lamp, focus lamp and etc.
- d. Objects behind the glass covered by beat and dust.
- e. Objects moving quickly
- f. Objects within large area and single color such as wall
- g. Objects that are too dark or faint

4.6.3 Iris Control

- The speed dome's default setting is for auto-adjust iris. It can make an adjustment quickly through auto detecting the beam change.
- User can adjust iris size manually through control keyboard to get required image brightness.
- User can renew auto iris after moving the joystick or sending additional commands through the controller (Attn: Suggest users to use auto iris).

Remark: When controlling the iris manually, the dome locks in its current control position and will not reset the auto-iris even if current object changes. You need to move the joystick or send control order to reset the auto iris.

4.6.4 Auto Backlight Compensation

Camera is divided into six areas to realize auto backlight compensation. In lighting conditions where a strong backlight exists, the speed dome will adjust the light levels relative to the foreground and background objects in order to achieve the highest resolution image. The camera is divided to 6 zones to best handle these unique lighting conditions.

4.6.5 Auto White Balance-

The speed dome will automatically adjust the white balance to contrast the changing background lighting conditions to achieve the truest digital color image.

V. Camera Menu Setting

Through the control keyboard , you can enter the speed dome camera menu setting.

1. Press FUN once, control keyboard displays:



2. Press FUN four times, control keyboard displays:

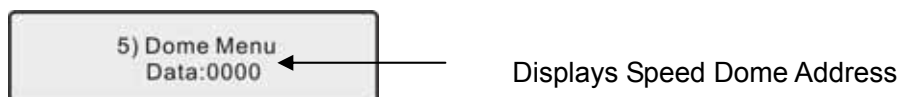

3. Press CLR to delete Original Data
4. Input desired speed dome Address, Press Enter

01. Use MON key (Page up) and SEQ key(page down) to select camera OSD. Press Ack key (confirmation), LIST (Select).

PELCO-D、PELCO-P、SAMSUNG、KALATEL protocol: Adjust preset position:No.55 and enter menu. Please refer to VI.

02. Take example for SONY camera to introduce each menu function (OUTDOOR SPEED DOME)**1)CAM ID:** (camera marking No.)**2)DZOOM:** OFF (Digital zoom switch)Press down LIST key, status from OFF \longleftrightarrow ON change**3)FOCUS:** AUTO (Auto Focus)Press down LIST key, status from AUTO (auto) \longleftrightarrow MAN (Manual) change**4)MIRROR:** OFF (Right-Left shift)Press down LIST key, status from OFF \longleftrightarrow ON change**5)NEGATIVE:** OFFPress down LIST key, status from OFF \longleftrightarrow ON change**6)ICR:** AUTO (B/W – color auto shift)Press down LIST key, status from AUTO (auto) \longleftrightarrow OFF change

When select AUTO status, the Day/Night dome camera will shift B/W image when the illumination is low. When select OFF, will not shift as B/W image.

7)COLOR: OFF (Color display)Press down LIST key, status from OFF \longleftrightarrow ON change**8)FREEZE:** ON (Picture Freeze)Press down LIST key, status from OFF \longleftrightarrow ON change**9)DISPAY:** OFF (Screen display)Press down LIST key, status from OFF \longleftrightarrow ON change**10)BACKLIGHT:** ONPress down LIST key, status from OFF \longleftrightarrow ON change**11)WBC MODE:** AUTO (whit balance)Press down LIST key, status from AUTO \longleftrightarrow INDOOR \longleftrightarrow OUTDOOR \longleftrightarrow MAN**12) RGAIN:** (Red gain)

Press down LIST key, showing “up” means red gain increase, “Down” means red gain decrease.

Press List key to cycle for 12 times.

13)BGAIN: (Blue gain)

Press down LIST key, showing “up” means blue gain increase, “Down” means blue gain decrease.

Press List key to cycle for 12 times.

14)EXPOSURE: (Exposure Select)Press down LIST key, status from AUTO \longleftrightarrow PRIORITY \longleftrightarrow MAN**15)BRIGHT:** (Brightness Adjustment)

Press down LIST key, showing “up” means brightness increase, “Down” means brightness decrease. Press List key to cycle for 12 times.

16)GAIN:

Press down LIST key, showing “up” means gain increase, “Down” means gain decrease. Press List key to cycle for 12 times.

17) SHUTTER:

Press down LIST key, showing “up” shutter increase, “Down” means shutter decrease. Press List key to cycle for 12 times.

18) IRIS: (Iris adjustment)

Press down LIST key, showing “up” iris increase, “Down” means iris decrease. Press List key to cycle for 12 times.

19)SET PRIVACY ZONE**20) EXPOSURE COMPENSATION: (Exposure compensation ON/OFF)**

Press down LIST key, status from OFF \longleftrightarrow ON

21) EXPOSURE COMPENSATION: (Exposure compensation adjustment)

Press down LIST key, showing “up” exposure compensation increase, “Down” means exposure compensation decrease. Press List key to cycle for 12 times.

22) SAVE SETTING(Set saving)

Press down ACK key and save current set, Press Area key, resume the camera

23)EXIT MENU(Exit menu)

Press down ACK key and exit the menu

03. Take example for SONY camera to introduce each menu function (INDOOR SPEED DOME)**1)CAM ID: (camera marking No.)****2)DZOOM: OFF (Digital zoom switch)**

Press down LIST key, status from OFF \longleftrightarrow ON change

3)FOCUS: AUTO (Auto Focus)

Press down LIST key, status from AUTO(auto) \longleftrightarrow MAN(Manual) change

4)MIRROR: OFF (Right-Left shift)

Press down LIST key, status from OFF \longleftrightarrow ON change

5)NEGATIVE: OFF

Press down LIST key, status from OFF \longleftrightarrow ON change

6)ICR: AUTO (B/W – color auto shift)

Press down LIST key, status from AUTO(auto) \longleftrightarrow OFF change

When select AUTO status, the Day/Night dome camera will shift B/W image when the illumination is low. When select OFF, will not shift as B/W image.

7)COLOR: OFF (Color display)

Press down LIST key, status from OFF \longleftrightarrow ON change

8)FREEZE: ON (Picture Freeze)

Press down LIST key, status from OFF \longleftrightarrow ON change

9)DISPAY: OFF (Screen display)

Press down LIST key, status from OFF \longleftrightarrow ON change

10)BACKLIGHT: ON

Press down LIST key, status from OFF \longleftrightarrow ON change

11)WBC MODE: AUTO (whit balance)

Press down LIST key, status from AUTO \longleftrightarrow INDOOR \longleftrightarrow OUTDOOR \longleftrightarrow MAN

12)BRIGHT:**13)RGAIN: (Red gain)****14)BGAIN: (Blue gain)****15)LOST POWER SAVE (Save set)**

Press down ACK key and save set

16)EXIT MENU

Press down ACK key and exit the menu

17)SET PRIVACY ZONE

This function can be optional.

VI. Protocol Order Chart

6.1 PELCO-D, PELCO-P Protocol Order Chart

P.S.: PELCO protocol has no relative order in control protocol because of part special function. In order to control some special function of dome, we make function shift to usual function. Usually adopt "adjust preset position/set preset position order" to make shift. Order shift chart see as below:

N Code	Keyboard Operations		N Code	Keyboard Operations	
	Adjust preset position: No. N	Set No. N preset position		Adjust preset position: No. N	Set No. N preset position
51	Start line scan (low speed)	Set start location of line scan	57	Cursor(down)	Delete No. 4 Preset position
52	Start line scan (mid- speed)	Set end location of line scan	58	Cursor(left)	Delete No.5 preset position
53	Start line scan (high-speed)	Set Guard Position	59	Cursor(right)	Delete No.6 preset position
54	Start auto-cruise (1-8 preset position)	Guard position open	60	Menu Data Select	Delete No.7 preset position
55	Into Menu	Guard position close	61	Menu data confirm	Delete No.8 preset position
56	Cursor (Up)	Delete No.3preset position	62		

6.2 SAMSUNG, KALATEL Protocol Order Chart

N Code	Keyboard Operations		N Code	Keyboard Operations	
	Adjust preset position: No. N	Set No. N preset position		Adjust preset position: No. N	
51	Start line scan (low speed)	Set start location of line scan	57	Cursor(down)	
52	Start line scan (mid- speed)	Set end location of line scan	58	Cursor(left)	
53	Start line scan (high-speed)		59	Cursor(right)	
54	Start auto-cruise (8th preset position)		60	Menu Data Select	
55	Into Menu		61	Menu data confirm	
56	Cursor (Up)		62		

For example: Use control keyboard to control speed dome PELCO protocol.

Set the protocol, address and baud rate to speed dome camera, make it same as that of the keyboard.

When Input 51, then input CALL, the dome will make the slow scanning between two points. If input 51, then input SHIFT+CALL, will enter starting point of line scanning(i.e. point 1).

If other some control device to control speed dome camera, Part of special function for Intelligent high speed dome can't be realized because of protocol limitation.

When other control device to control speed dome camera, need set protocol, address and baud rate correctly. When you set address, please set the speed dome protocol 1 more than other control device.

For example: DVR address is 1, dome camera address should be set as 2 for normal control.

VII Exception Handling

Issue	Possible Reason	Solution
Power on, no movement, no image, indicator light does not light	Power line connected wrong	Correct it
	Power damaged	Replace
	Blowout	Replace
	Power line be connected bad	Check it
Power on, self check, has image, can't control, indicator light does not flicker	The machine's address code or baud rate is wrong	Reset
	Protocol wrong	Correct it
	RS485 bus be connected wrong	Check it
Camera can't reposition itself. (camera can no longer move)	Mechanical failure	Repair it
	Camera incline	Correct it
	Power is not enough	Replace
Image is not stable	Video line connected bad	Check it
	Power is not enough	Replace
Image is dim	Focus in manual state	Operate the machine or adjust a preset position
	Dome is dirty	Clean it

VIII. Address-Binary code chart

Binary System Code	VTS	SAMSUNG	Binary System Code	VTS	SAMSUNG	Binary System Code	VTS	SAMSUNG
	PELCO-D	KALATEL		PELCO-D	KALATEL		PELCO-D	KALATEL
	PELCO-P			PELCO-P			PELCO-P	
00000000	1	0	00010110	23	22	00101100	45	44
00000001	2	1	00010111	24	23	00101101	46	45
00000010	3	2	00011000	25	24	00101110	47	46
00000011	4	3	00011001	26	25	00101111	48	47
00000100	5	4	00011010	27	26	00110000	49	48
00000101	6	5	00011011	28	27	00110001	50	49
00000110	7	6	00011100	29	28	00110010	51	50
00000111	8	7	00011101	30	29	00110011	52	51
00001000	9	8	00011110	31	30	00110100	53	52
00001001	10	9	00011111	32	31	00110101	54	53
00001010	11	10	00100000	33	32	00110110	55	54
00001011	12	11	00100001	34	33	00110111	56	55
00001100	13	12	00100010	35	34	00111000	57	56
00001101	14	13	00100011	36	35	00111001	58	57
00001110	15	14	00100100	37	36	00111010	59	58
00001111	16	15	00100101	38	37	00111011	60	59
00010000	17	16	00100110	39	38	00111100	61	60
00010001	18	17	00100111	40	39	00111101	62	61
00010010	19	18	00101000	41	40	00111110	63	62
00010011	20	19	00101001	42	41	00111111	64	63
00010100	21	20	00101010	43	42	01000000	65	64

00010101	22	21	00101011	44	43	01000001	66	65
Binary System Code	VTS PELCO-D PELCO-P	SAMSUNG KALATEL	Binary System Code	VTS PELCO-D PELCO-P	SAMSUNG KALATEL	Binary System Code	VTS PELCO-D PELCO-P	SAMSUNG KALATEL
01000010	67	66	01101100	109	108	10010110	151	150
01000011	68	67	01101101	110	109	10010111	152	151
01000100	69	68	01101110	111	110	10011000	153	152
01000101	70	69	01101111	112	111	10011001	154	153
01000110	71	70	01110000	113	112	10011010	155	154
01000111	72	71	01110001	114	113	10011011	156	155
01001000	73	72	01110010	115	114	10011100	157	156
01001001	74	73	01110011	116	115	10011101	158	157
01001010	75	74	01110100	117	116	10011110	159	158
01001011	76	75	01110101	118	117	10011111	160	159
01001100	77	76	01110110	119	118	10100000	161	160
01001101	78	77	01110111	120	119	10100001	162	161
01001110	79	78	01111000	121	120	10100010	163	162
01001111	80	79	01111001	122	121	10100011	164	163
01010000	81	80	01111010	123	122	10100100	165	164
01010001	82	81	01111011	124	123	10100101	166	165
01010010	83	82	01111100	125	124	10100110	167	166
01010011	84	83	01111101	126	125	10100111	168	167
01010100	85	84	01111110	127	126	10101000	169	168
01010101	86	85	01111111	128	127	10101001	170	169
01010110	87	86	10000000	129	128	10101010	171	170
01010111	88	87	10000001	130	129	10101011	172	171
01011000	89	88	10000010	131	130	10101100	173	172
01011001	90	89	10000011	132	131	10101101	174	173
01011010	91	90	10000100	133	132	10101110	175	174
01011011	92	91	10000101	134	133	10101111	176	175
01011100	93	92	10000110	135	134	10110000	177	176
01011101	94	93	10000111	136	135	10110001	178	177
01011110	95	94	10001000	137	136	10110010	179	178
01011111	96	95	10001001	138	137	10110011	180	179
01100000	97	96	10001010	139	138	10110100	181	180
01100001	98	97	10001011	140	139	10110101	182	181
01100010	99	98	10001100	141	140	10110110	183	182
01100011	100	99	10001101	142	141	10110111	184	183
01100100	101	100	10001110	143	142	10111000	185	184
01100101	102	101	10001111	144	143	10111001	186	185
01100110	103	102	10010000	145	144	10111010	187	186
01100111	104	103	10010001	146	145	10111011	188	187
01101000	105	104	10010010	147	146	10111100	189	188
01101001	106	105	10010011	148	147	10111101	190	189
01101010	107	106	10010100	149	148	10111110	191	190
01101011	108	107	10010101	150	149	10111111	192	191

Binary System Code	VTS PELCO-D PELCO-P	SAMSUNG KALATEL	Binary System Code	VTS PELCO-D PELCO-P	SAMSUNG KALATEL	Binary System Code	VTS PELCO-D PELCO-P	SAMSUNG KALATEL
11000000	193	192	11010110	215	214	11101011	236	235
11000001	194	193	11010111	216	215	11101100	237	236
11000010	195	194	11011000	217	216	11101101	238	237
11000011	196	195	11011001	218	217	11101110	239	238
11000100	197	196	11011010	219	218	11101111	240	239
11000101	198	197	11011011	220	219	11110000	241	240
11000110	199	198	11011100	221	220	11110001	242	241
11000111	200	199	11011101	222	221	11110010	243	242
11001000	201	200	11011110	223	222	11110011	244	243
11001001	202	201	11011111	224	223	11110100	245	244
11001010	203	202	11100000	225	224	11110101	246	245
11001011	204	203	11100001	226	225	11110110	247	246
11001100	205	204	11100010	227	226	11110111	248	247
11001101	206	205	11100011	228	227	11111000	249	248
11001110	207	206	11100100	229	228	11111001	250	249
11001111	208	207	11100101	230	229	11111010	251	250
11010000	209	208	11100110	231	230	11111011	252	251
11010001	210	209	11100111	232	231	11111100	253	252
11010010	211	210	11101000	233	232	11111101	254	253
11010011	212	211	11101001	234	233	11111110	255	254
11010100	213	212	11101010	235	234	11111111	256	255
11010101	214	213						